

Village of Lake Isabella
1010 Clubhouse Drive
Lake Isabella, MI, 48893

Resolution 2008-31
Lake Isabella Street Sign Standards

Whereas; the Village of Lake Isabella maintains over 27 miles of streets; and,

Whereas; the Village of Lake Isabella desires to install and maintain traffic signs which enhance the aesthetic quality of the community and assist motorists in safe passage; and,

Now therefore be it resolved;

The Village of Lake Isabella hereby adopts the following minimum as standards for street signs:

All regulatory signs shall be of at least “reflective” grade.

Street nameplates shall be at least 9” in height and “reflective” grade.

Street nameplate signs shall be set apart from other regulatory and advisory signs. When wood posts are used, they shall be capped with a copper end cap.

Whenever possible, signs shall be placed on wood or vinyl posts, which shall be painted white.

Installation guidelines for wood posts are included on the attached sheet.

Stop, yield, and caution signs shall be 30” in height.

Wood posts shall feature two “break-away” holes, as shown on the attached illustration.

I, Jeffrey P. Grey, the duly qualified and acting Clerk of the Village of Lake Isabella, Isabella County, Michigan (the “Village”) do hereby certify that the foregoing is a true and complete copy of a resolution adopted by the Village Council at a meeting held on January 20, 2009, the original of which is on file in the Village Office. Public notice of said meeting was given pursuant to and in compliance with Act No. 267 of the Public Acts of Michigan of 1976, as amended.

Date

Jeffrey P. Grey
Lake Isabella Village Clerk

Timothy R. Wolff
Lake Isabella Village Manager

Resolution 2008-31 Lake Isabella Street Sign Standards

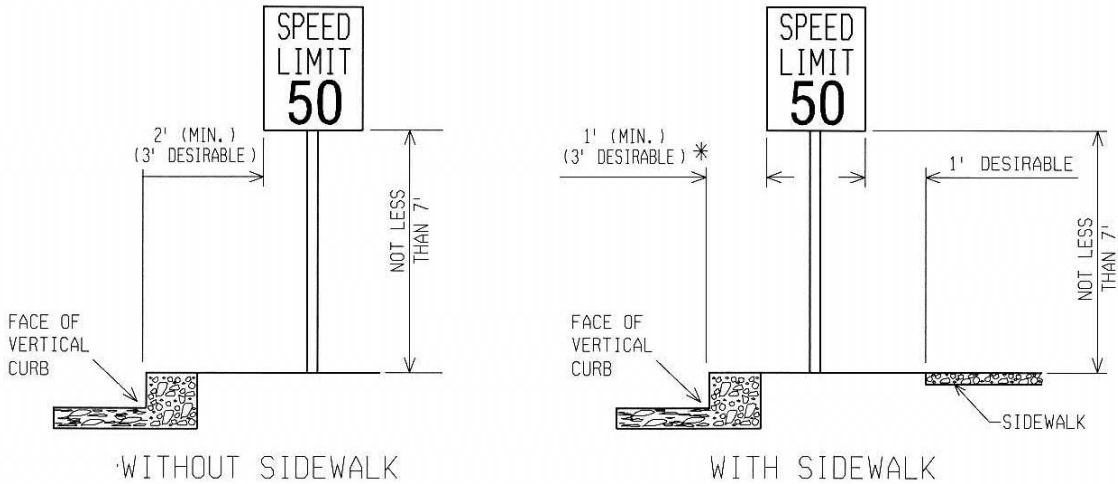

* WHEN DIRECTED BY THE ENGINEER, 1' IS PERMITTED IN AREAS WHERE SIDEWALK OR UTILITY POLES ARE CLOSE TO CURB PER MMUTCD.

NOTE: SLOPING CURBS SHOULD BE TREATED AS FLAT.

(4" X 4" (NOMINAL) POST) 1" DIA. 2 HOLES
 (4" X 6" (NOMINAL) POST) 2" DIA. 2 HOLES

THE POST MAY BE DRIVEN OR PLACED IN AN AUGERED HOLE. IF AUGERED, BACKFILL WITH EXISTING MATERIAL IN 12" DEEP LAYERS, TAMPING EACH LAYER.

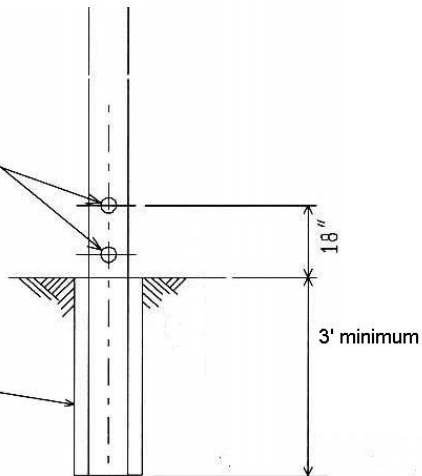

END VIEW
WOOD POST DIRECT EMBEDMENT DETAIL
SINGLE POST INSTALLATIONS ONLY